

4-CABLE FLOOR TO CEILING DG-25-SCU-SAT SHELVING/SIGN ASSEMBLY

BILL OF MATERIALS		
ITEM #	GRIPLOCK P/N	QTY.
1	DG-CC-APLT-SAT	4
2	DAS-25-71-xxx*	4
3	DG-GC-SAT	2
4	DG-25-SCU-SAT	14
5	DG-TNS-APLT-SAT	4

*xxx is length of cable in inches.
Stock lengths are 60", 120", 180" & 240"

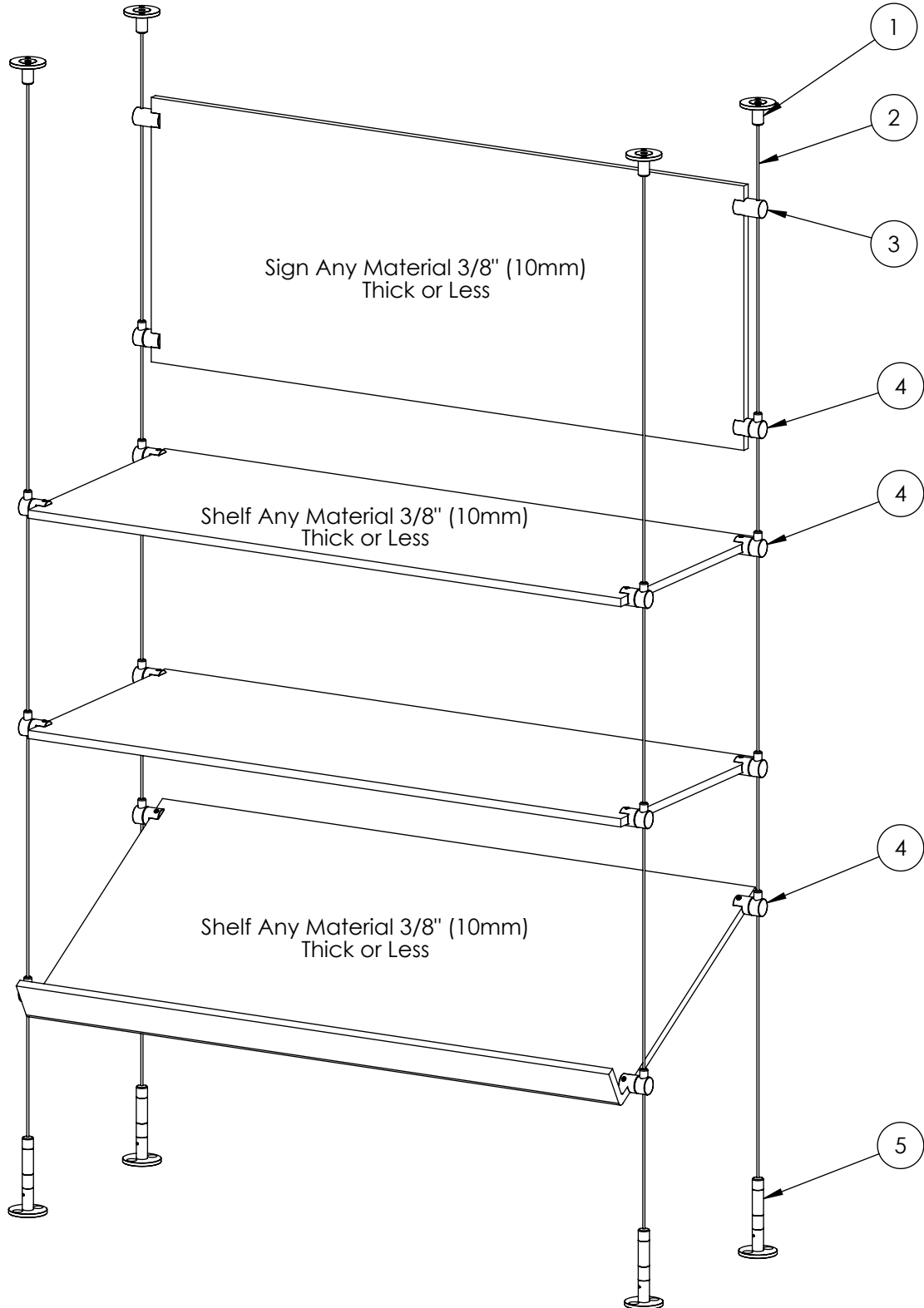

DATE: 09/02/08
SCALE: 1:7
FILE: Sign-Shelf Side Clamp System.
Floor & Ceiling Anchor Plates

PROPRIETARY AND CONFIDENTIAL
This drawing and these specifications are the exclusive property of GRIPLOCK SYSTEMS LLC and shall not be divulged, reproduced, copied, or used as the basis for the manufacture or sale of apparatus without the express written authorization of GRIPLOCK SYSTEMS LLC.



GRIPLOCK SYSTEMS
410 Palm Ave. Loft A18, Carpinteria, CA 93013
Phone (805) 566-0064 Fax (805) 566-0065
www.griplocksystems.com

4-CABLE SHELVING SYSTEM WITH SIDE CLAMPS

BILL OF MATERIALS		
ITEM #	GRIPLOCK P/N	QTY.
1	DG-CC-SAT	4
2	DAS-25-71-xxx*	4
3	DG-25-SCU-SAT	16
4	DG-TNS-SAT	4

*xxx is length of cable in inches.
Stock lengths are 60", 120", 180" & 240"

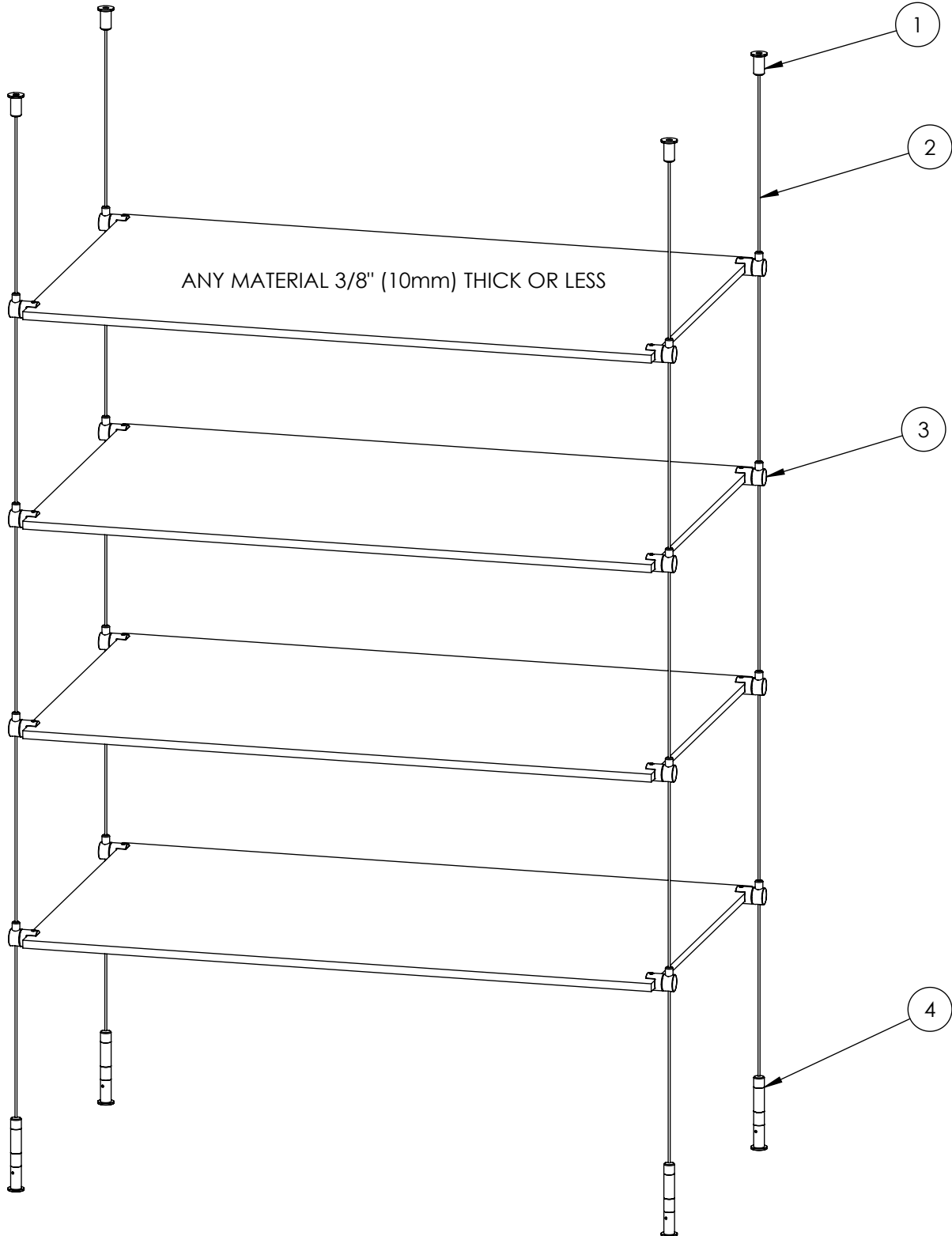

DATE: 07/15/08
SCALE: 1:7
FILE: Floor to Ceiling Shelving w
DG-25-SCU-SAT

PROPRIETARY AND CONFIDENTIAL
This drawing and these specifications are the exclusive property of GRIPLOCK SYSTEMS INC. and shall not be divulged, reproduced, copied, or used as the basis for the manufacture or sale of apparatus without the express written authorization of GRIPLOCK SYSTEMS INC.



GRIPLOCK SYSTEMS
410 Palm Ave. Loft A18, Carpinteria, CA 93013
Phone (805) 566-0064 Fax (805) 566-0065
www.griplocksystems.com

2-CABLE FLOOR TO CEILING SIGN SYSTEM WITH SIDE CLAMPS

BILL OF MATERIALS		
ITEM #	GRIPLOCK P/N	QTY.
1	DG-CC-CPLT-SAT	2
2	DAS-20-87-xxx*	2
3	DG-GC-SAT	2
4	DG-25-SCU-SAT	2
5	DG-TNS-CPLT-SAT	2

*xxx is length of cable in inches.
Stock lengths are 60", 120", 180" & 240"

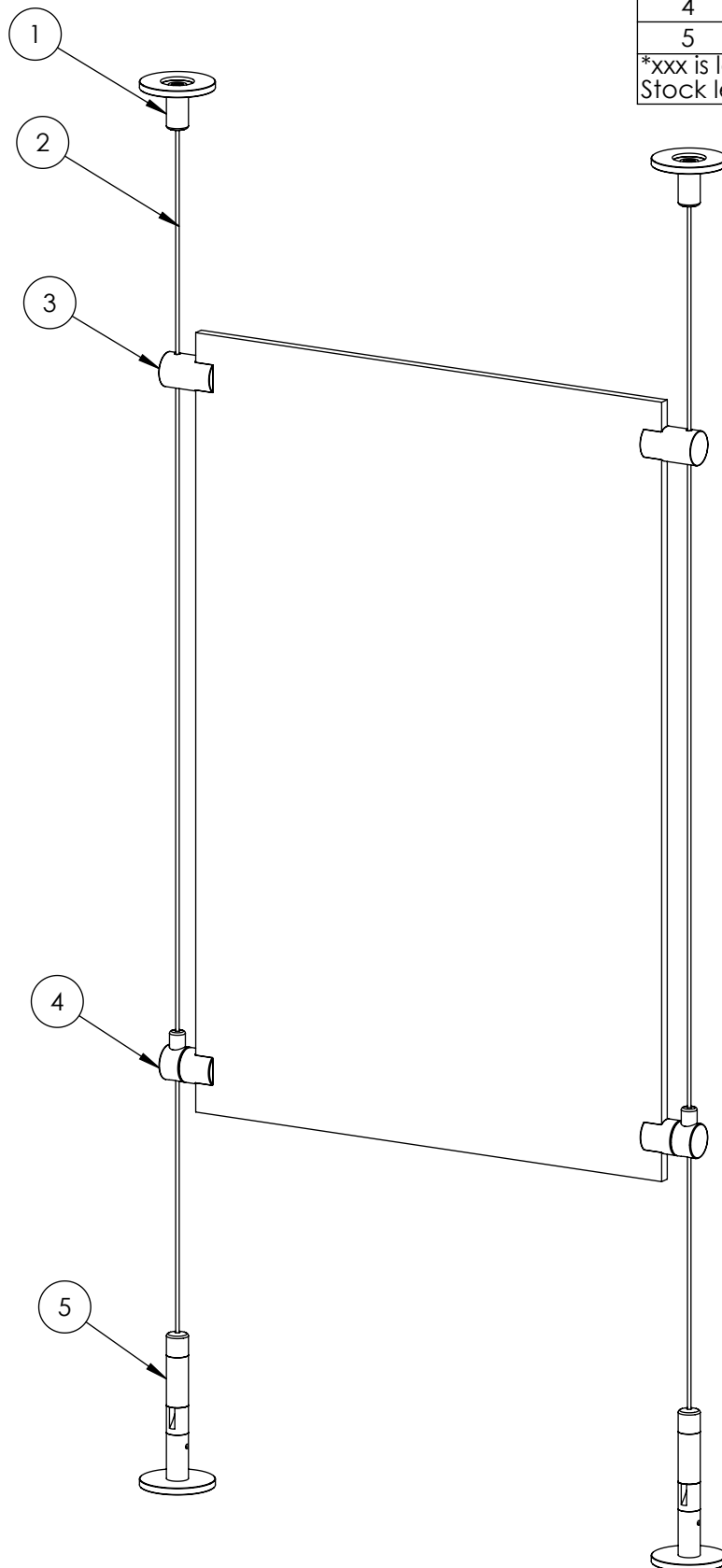

DATE: 07/17/08

SCALE: 1:4

FILE: 2 Cable Floor to Ceiling
Sign Clamps & CPLT

PROPRIETARY AND CONFIDENTIAL

This drawing and these specifications are the exclusive property of GRIPLOCK SYSTEMS INC. and shall not be divulged, reproduced, copied, or used as the basis for the manufacture or sale of apparatus without the express written authorization of GRIPLOCK SYSTEMS INC.



GRIPLOCK SYSTEMS

410 Palm Ave. Loft A18, Carpinteria, CA 93013
Phone (805) 566-0064 Fax (805) 566-0065
www.griplocksystems.com